

# 12LW1400

## Extended Low Frequency Transducer

### Key Features

- 96 dB SPL 1W / 1m average sensitivity
- 100 mm (4 in) Interleaved Sandwich Voice coil (ISV)
- 900 W AES power handling
- Double Silicon Spider (DSS) for improved excursion control and linearity
- Double Demodulating Ring (DDR) for lower distortion
- Improved heat dissipation via unique basket design
- Weather protected cone and plates for outdoor usage
- Specially designed for high loading compact subwoofers



### General Description

The 12LW1400 is an extended low frequency loudspeaker which sets a new industry standard in 12" (300 mm) 4" voice coil high performance transducers, already accomplished by the 15LW1400 and 18LW1400 respectively. The transducer has been designed for subwoofer or low frequency component usage in multi-way systems where considerable amounts of power and low distortion are needed. 12LW1400 is ideally suited for very high loading cabinets, such as bandpass, horn loaded or compact reflex configurations. In its reflex configuration, 12LW1400 can be used in extremely compact enclosures (30 - 60 lt), making it the ideal choice for touring applications, sound reinforcement or fixed installations, including indoor and outdoor concert reinforcement systems.

Maximum strength, smooth response and high displacement piston motion are obtained using Double Silicon Spider technology (DSS) and a large excursion surround.

A special formulation cone material has been used to enable it to withstand high loading and high power peaks. The suspension system has been designed to give symmetric large signal behavior across the whole working range, providing low harmonic distortion at different excitation levels.

An inside outside aluminum voice coil, based on Interleaved Sandwich Voice coil (ISV) provides high levels of thermal stability and durability. The ISV technology is based on a high strength fiberglass former with half the coil wound on the outside and half on the inside ensuring uniform thermal dissipation on both sides. It is bonded together using unique high temperature resin adhesive to achieve a balanced and solid linear motor unit.

Double Demodulation Rings (DDR) technology dramatically reduces the intermodulation and harmonic distortion whilst improving the transient response.

The top plate and back plate design have been optimized for cone excursion and maximum symmetric force factor by the use of in-house FEA Magnetic simulation software. Furthermore, excellent heat dissipation has been achieved by the special basket design which incorporates air channels between the basket and magnetic top plate.

The 12LW1400 exclusive cone treatment improves pulp strength and gives water repellent properties to both sides of the cone. In addition, the special coating of both the top and back plates makes them far more resistant to the corrosive effects of salts and oxidization than standard zinc-coated treatment.

0221283110 8 Ohm

0271283110 R-kit 8 Ohm

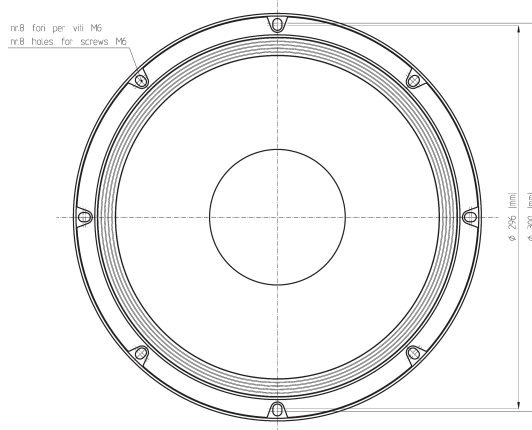
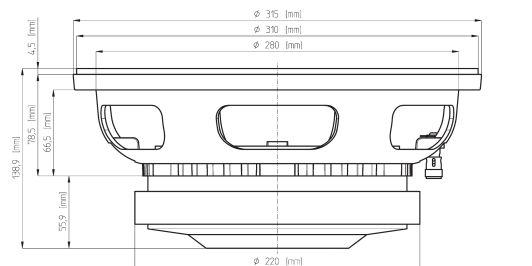

FERRITE LF-MB-MF TRANSDUCERS

# 12LW1400

Extended Low Frequency Transducer

## GENERAL SPECIFICATIONS

NOMINAL DIAMETER	300 mm (12 in)
RATED IMPEDANCE	8 Ohm
AES POWER (1)	900W
PROGRAM POWER (2)	1400 W
PEAK POWER (3)	6000 W
SENSITIVITY (4)	96 dB
FREQUENCY RANGE (5)	51 ÷ 4000 Hz
POWER COMPRESSION @-10DB (6)	0,5 dB
POWER COMPRESSION @-3DB	2,2 dB
POWER COMPRESSION@FULL POWER	3 dB
MAX RECOMM. FREQUENCY	1000 Hz
RECOMM. ENCLOSURE VOLUME	30 ÷ 60 lt. (1,06 ÷ 2,12 cuft)
MINIMUM IMPEDANCE	6,8 Ohm at 25°C
MAX PEAK TO PEAK EXCURSION	36 mm (1,4 in)
VOICE COIL DIAMETER	100 mm (4 in)
VOICE COIL WINDING MATERIAL	aluminum
SUSPENSION	Triple roll, Polycotton
CONE	Straight, Paper

## THIELE SMALL PARAMETERS (7)

Fs	45 Hz
Re	5,2 Ohm
Sd	0,053 sq.mt. (82,15 sq.in.)
Qms	5
Qes	0,32
Qts	0,3
Vas	55 lt. (1,94 cuft)
Mms	88 gr. (0,19 lb)
BL	20 Tm
Linear Mathematical Xmax (8)	± 8,25 mm (± 0,32 in)
Le (1kHz)	1,5 mH
Ref. Efficiency 1W@1m (half space)	1,5% (94 dB)

## MOUNTING INFORMATION

Overall diameter	315 mm (12,4 in)
N. of mounting holes	8
Mounting holes diameter	7,15 mm (0,28 in)
Bolt circle diameter	296 - 300 mm (11,65 - 11,8 in)
Front mount baffle cutout ø	282 mm (11,1 in)
Rear mount baffle cutout ø	282 mm (11,1 in)
Total depth	141 mm (5,55 in)
Flange and gasket thickness	17,5 mm (0,69 in)
Net weight	10,9 kg (26,5 lb)
Shipping weight	11,5 kg (27,8 lb)
CardBoard Packaging dimensions	332 x 332 x 184 mm (13,07 x 13,07 x 7,24 in)

**FREQUENCY RESPONSE CURVE OF 12LW1400 MADE ON 50 LIT. ENCLOSURE TUNED 60 HZ IN FREE FIELD (4PI) ENVIRONMENT. ENCLOSURE CLOSES THE REAR OF THE DRIVER. THE THIN LINE REPRESENTS 45 DEG. OFF AXIS FREQUENCY RESPONSE**

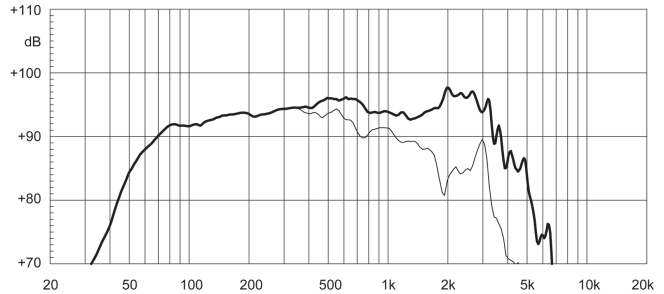

**FREE AIR IMPEDANCE MAGNITUDE CURVE**

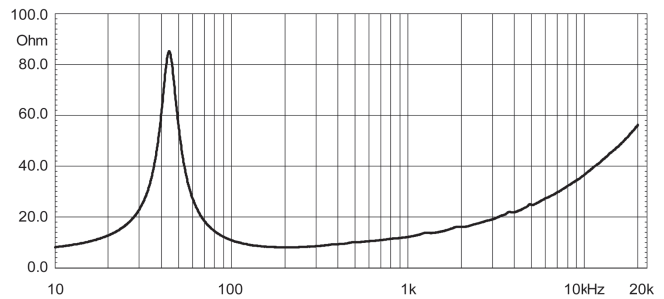

### NOTES

- (1) AES power is determined according to AES2-1984 (r2003) standard
- (2) Program power rating is measured in 50 lit enclosure tuned 60Hz using a 40 - 400Hz band limited pink noise test signal with 50% duty cycle, applied for 2 hours.
- (3) The peak power rating represents the maximum permitted instantaneous peak power level over a maximum period of 10ms which will be withstood by the loudspeaker without damage.
- (4) Sensitivity represents the averaged value of acoustic output as measured on the forward central axis of cone, at distance 1m from the baffle panel, when connected to 2,83 V sine wave test signal swept between 100Hz and 500Hz with the test specimen mounted in the same enclosure as given for (1) above.
- (5) Frequency range is given as the band of frequencies delineated by the lower and upper limits where the output level drops by 10 dB below the rated sensitivity in half space environment.
- (6) Power compression represents the loss of sensitivity for the special power, measured from 50-500 Hz, after a 5 min pink noise preconditioning test at the specified power.
- (7) Thiele - Small parameters are measured after the test specimen has been conditioned by 900 W AES power and represent the expected long term parameters after a short period of use.
- (8) Linear Math. Xmax is calculated as  $(Hvc-Hg)/2Hg/4$  where Hvc is the coil depth and Hg is the gap depth.

Eighteen Sound engages in research and product improvement. New materials and design refinements can be introduced into existing products without notice.