

# 12LW801

## Extended Low Frequency Transducer

### Key Features

- 96 dB SPL 1W / 1m average sensitivity
- 75 mm (3 in) Interleaved Sandwich Voice coil (ISV)
- 500W AES power handling
- Weather protected cone and plates for outdoor usage
- Double Silicon Spider (DSS) for improved control and linearity
- Improved heat dissipation via unique basket design
- Ideal for compact reflex subwoofers



### General Description

The 12LW801 is a 12" low frequency driver, achieving high SPL at low frequencies with reduced THD.

The 12LW801 has been designed for use as a low bass or sub-woofer component, in either highly compact reflex, bandpass or horn loaded configurations. It provides clean, linear frequency reproduction at high power levels, or as part of a compact high power fullrange system. In its reflex configuration, it can be used in extremely compact enclosures (40 – 70 lt), making it ideal for portable applications, such as road shows or use with bass musical instruments.

The high excursion capabilities of the double-action roll surround and suspension system, in conjunction with Eighteen Sound's Double Silicon Spider technology (DSS), enable the 12LW801 to achieve exceptionally high levels of linear travel for a 12" unit.

With its custom design surround, the carbon fiber reinforced curvilinear ribbed cone assures smooth response and exceptional strength, with maximum reliability under high mechanical stress.

The 75 mm state-of-the-art voice coil is similar to that of our 18LW1400 top-of-the-range model. It employs Interleaved Sandwich Voice coil (ISV), in which a high strength fiberglass former carries windings on both its outer and inner surfaces, resulting in a mass balanced coil and providing a uniform motive drive. This, in conjunction with the use of unique high temperature resin adhesives, creates an extremely linear motor assembly with a reduced tendency for break-up under hard drive conditions.

Excellent heat dissipation has been achieved by incorporating air channels between the basket and the top plate.

Maximum flux concentration and force factor in the gap is assured by the unique shape and design of the top and back plates, designed using our in-house Magnetic Flux FEA CAD resource.

Due to the increasing use of high power audio systems at outdoor events or in marine environments, the ability to perform properly under inclement weather conditions is an essential part of the Eighteen Sound philosophy. This is achieved using an exclusive cone treatment which improves pulp strength and gives water repellent properties to the cone. In addition, a special treatment is applied to the top and back plates making the loudspeaker resistant to the corrosive effects of salts and oxidization. This treatment is more effective than after any other treatment in use today.

0221283220 8ohm  
0221243220 4ohm

0271283220 R-kit 8ohm  
0271243220 R-kit 4ohm

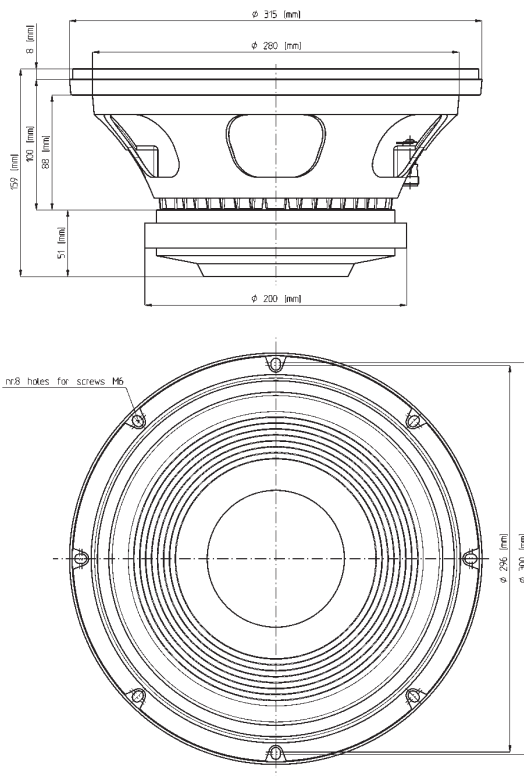

FERRITE LF-MB-MF TRANSDUCERS

# 12LW801

Extended Low Frequency Transducer

## GENERAL SPECIFICATIONS

NOMINAL DIAMETER	300 mm (12 in)
RATED IMPEDANCE	8 Ohm
AES POWER	500 W
PROGRAM POWER (1)	800 W
PEAK POWER (2)	4000 W
SENSITIVITY (3)	96 dB
FREQUENCY RANGE (4)	40 ÷ 4000 Hz
POWER COMPRESSION @-10DB (5)	0,8 dB
POWER COMPRESSION @-3DB	2,3 dB
POWER COMPRESSION @0DB	3,9 dB
MAX RECOMM. FREQUENCY	1000 Hz
RECOMM. ENCLOSURE VOLUME	40 ÷ 100 lt. (1,41 ÷ 3,53 cuft)
MINIMUM IMPEDANCE	6,1 Ohm at 25°C
MAX PEAK TO PEAK EXCURSION	34 mm (1,34 in)
VOICE COIL DIAMETER	75 mm (2,95 in)
VOICE COIL WINDING MATERIAL	copper
SUSPENSION	Single roll, rubber
CONE	Curvilinear ribbed, treated paper

## THIELE SMALL PARAMETERS (6)

Fs	54 Hz
Re	5 Ohm
Sd	0,0531 sq.mt. (82,31 sq.in.)
Qms	9
Qes	0,34
Qts	0,33
Vas	41 lt. (1,7 cuft)
Mms	84 gr. (0,17 lb)
BL	20,3 Tm
Linear Mathematical Xmax (7)	±8 mm (± 0,31 in)
Le (1kHz)	1,7 mH
Ref. Efficiency 1W@1m (half space)	94,7 dB

## MOUNTING INFORMATION

Overall diameter	315 mm (12,4 in)
N. of mounting holes	8
Mounting holes diameter	7,15 mm (0,28 in)
Bolt circle diameter	296 - 300 mm (11,65 - 11,8 in)
Front mount baffle cutout ø	282 mm (11,1 in)
Rear mount baffle cutout ø	282 mm (11,1 in)
Total depth	159 mm (6,25 in)
Flange and gasket thickness	20 mm (0,79 in)
Net weight	8,1 kg (17,88 lb)
Shipping weight	8,9 kg (19,65 lb)
CardBoard Packaging dimensions	332 x 332 x 184 mm (13,07 x 13,07 x 7,24 in)

FREQUENCY RESPONSE CURVE OF 12LW801 MADE ON 50 LIT. ENCLOSURE TUNED 60HZ IN FREE FIELD (4PI) ENVIRONMENT. ENCLOSURE CLOSES THE REAR OF THE DRIVER. THE THIN LINE REPRESENTS 45 DEG. OFF AXIS FREQUENCY RESPONSE.

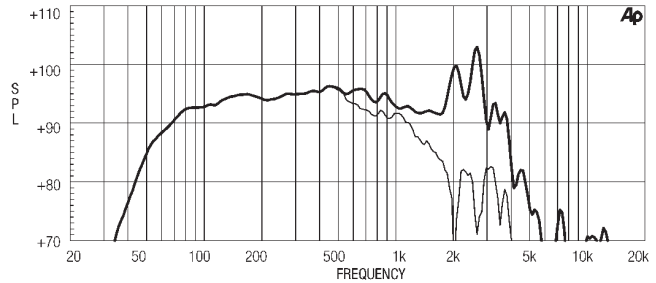

FREE AIR IMPEDANCE MAGNITUDE CURVE.

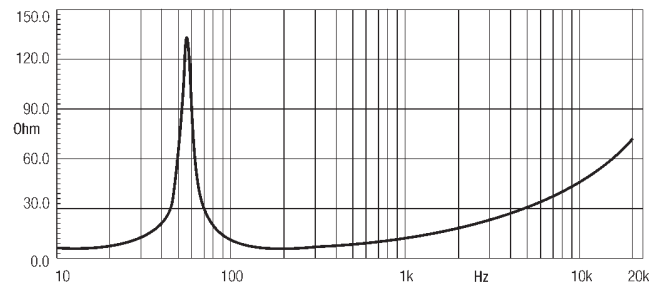

### NOTES

- (1) Program power rating is measured in 50 lit enclosure tuned 60Hz using a 40 - 400Hz band limited pink noise test signal with 50% duty cycle, applied for 2 hours.
- (2) The peak power rating is based on a 10dB crest factor above the continuous power rating and represents the maximum permitted instantaneous peak power level over a maximum period of 10ms which will be withstood by the loudspeaker without damage.
- (3) Sensitivity represents the averaged value of acoustic output as measured on the forward central axis of cone, at distance 1m from the baffle panel, when connected to 2,83V sine wave test signal swept between 100Hz and 500Hz with the test specimen mounted in the same enclosure as given for 2 above.
- (4) Frequency range is given as the band of frequencies delineated by the lower and upper limits where the output level drops by 10 dB below the rated sensitivity in half space environment.
- (5) Power compression represents the loss of sensitivity for the specified power, measured from 50-500 Hz, after a 5 min pink noise preconditioning test at the specified power.
- (6) Thiele - Small parameters are measured after the test specimen has been conditioned by 500 W AES power and represent the expected long term parameters after a short period of use.
- (7) Linear Mat. Xmax is calculated as;  $(Hvc-Hg)/2 + Hg/4$  where Hvc is the coil depth and Hg is the gap depth.

Eighteen Sound engages in research and product improvement. New materials and design refinements can be introduced into existing products without notice.