

# 15LW1500

## Extended Low Frequency Transducer

### Key Features

- 96 dB SPL 1W / 1m average sensitivity
- 100 mm (4 in) Interleaved Sandwich Voice coil (ISV)
- 1000 W AES power handling
- Double Silicon Spider (DSS) for improved excursion control and linearity
- Improved heat dissipation via unique basket design
- Weather protected cone and plates for outdoor usage
- Ideal for very low distortion, studio quality subwoofer



### General Description

The 15LW1500 is a low frequency loudspeaker which sets a new industry standard in 15" (380 mm) high performance transducers, achieving a remarkable 34 Hz downwards extension with 96 dB average sensitivity and handling peak power levels of 7000 W.

The 15LW1500 has been designed for use as a low bass or subwoofer component in either highly compact reflex, bandpass or horn loaded configurations. It provides clean, linear frequency reproduction at high power levels, as part of a compact high power fullrange system. In its reflex configuration, it can be used in extremely compact enclosures (75 lt) making it also suitable for portable applications, such as, road shows and bass musical instruments.

The low noise and high excursion capabilities of the double-action roll surround and suspension system, in conjunction with the Eighteen Sound Double Silicon Spider (DSS), enable the 15LW1500 to achieve very high levels of linear travel for a 15" unit.

The already low distortion and unmistakable sound quality of this loudspeaker is further improved using Double Demodulating Rings (DDR), designed to dramatically reduce the intermodulation and harmonic distortion while improving the transient response.

The 100mm copper voice coil employs the Interleaved Sandwich Voice coil (ISV) technology, in which a high strength fibreglas former carries windings on both the outer and inner surfaces to achieve a balanced coil with a uniform distribution of mass and motive energy that results in an extremely linear motor assembly.

The carbon fiber reinforced straight ribbed cone assures smooth response and exceptional strength with maximum reliability under high mechanical stress.

Excellent heat dissipation has been achieved by incorporating air channels between the basket and top plate of the magnet. Further ventilation is provided using air vents in the back plate to direct air into the lower part of the voice coil gap.

Due to the increase in use of high power audio systems at outdoor events or in marine environments, the ability to perform properly under inclement weather conditions is a key feature in the Eighteen Sound philosophy. This has been achieved thanks to an exclusive cone treatment improving pulp strength which gives water repellent properties to both sides of the cone. In addition, a special treatment is applied to the top and back plates which is far more resistant to the corrosive effects of salts and oxidization than any other treatment in use today.

0221583140 8 Ohm

0271583140 R-kit 8 Ohm

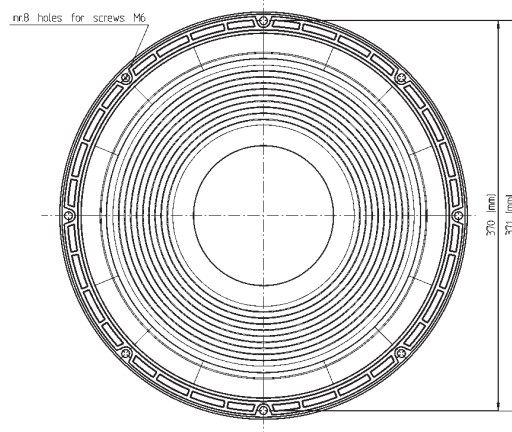
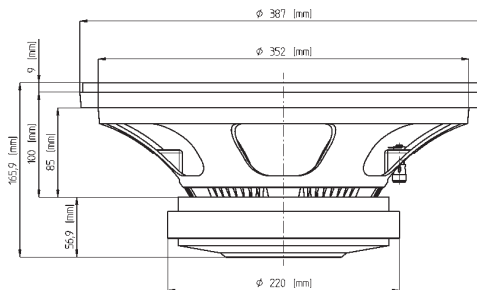

FERRITE LF-MB-MF TRANSDUCERS

# 15LW1500

Extended Low Frequency Transducer

## GENERAL SPECIFICATIONS

NOMINAL DIAMETER	380 mm (15 in)
RATED IMPEDANCE	8 Ohm
AES POWER (1)	1000 W
PROGRAM POWER (2)	1400 W
PEAK POWER (3)	7000 W
SENSITIVITY (4)	96 dB
FREQUENCY RANGE (5)	40 ÷ 2000 Hz
POWER COMPRESSION @-10DB (6)	0,7 dB
POWER COMPRESSION @-3DB	2,3 dB
POWER COMPRESSION @FULL POWER	3,2 dB
MAX RECOMM. FREQUENCY	500 Hz
RECOMM. ENCLOSURE VOLUME	70 ÷ 140 lt. (2,47 ÷ 4,95 cuft)
MINIMUM IMPEDANCE	6,7 Ohm at 25°C
MAX PEAK TO PEAK EXCURSION	39 mm (1,53 in)
VOICE COIL DIAMETER	100 mm (4 in)
VOICE COIL WINDING MATERIAL	copper
SUSPENSION	Single roll, Rubber
CONE	Straight ribbed, Paper

## THIELE SMALL PARAMETERS (7)

Fs	34 Hz
Re	5 Ohm
Sd	0,090 sq.mt. (139,5 sq.in.)
Qms	11,5
Qes	0,29
Qts	0,28
Vas	195 lt. (6,9 cuft)
Mms	130 gr. (0,63 lb)
BL	22,1 Tm
Linear Mathematical Xmax (8)	± 9 mm (±0,35 in)
Le (1kHz)	2,4 mH
Ref. Efficiency 1W@1m (half space)	96,2 dB

## MOUNTING INFORMATION

Overall diameter	387 mm (15,23 in)
N. of mounting holes	8
Mounting holes diameter	7,15 mm (0,28 in)
Bolt circle diameter	370 - 371 mm (14,55 - 14,6 in)
Front mount baffle cutout ø	353 mm (13,90 in)
Rear mount baffle cutout ø	357 mm (14,06 in)
Total depth	165,9 mm (6,53 in)
Flange and gasket thickness	24 mm (0,94 in)
Net weight	12,4 kg (27,37 lb)
Shipping weight	13,4 kg (29,58 lb)
CardBoard Packaging dimensions	405 x 405 x 214 mm (15,94 x 15,94 x 8,43 in)

FREQUENCY RESPONSE CURVE OF 15LW1500 MADE ON 125 LIT. ENCLOSURE TUNED 50HZ IN FREE FIELD (4PI) ENVIRONMENT. ENCLOSURE CLOSES THE REAR OF THE DRIVER. THE THIN LINE REPRESENTS 45 DEG. OFF AXIS FREQUENCY RESPONSE.

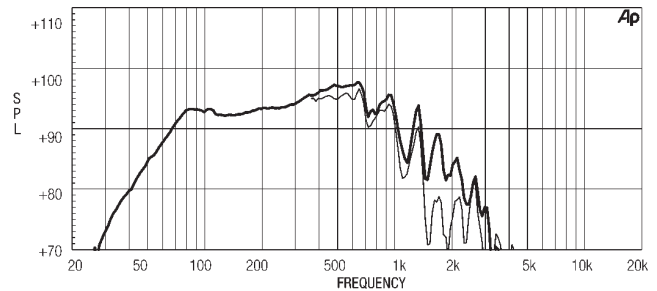

FREE AIR IMPEDANCE MAGNITUDE CURVE

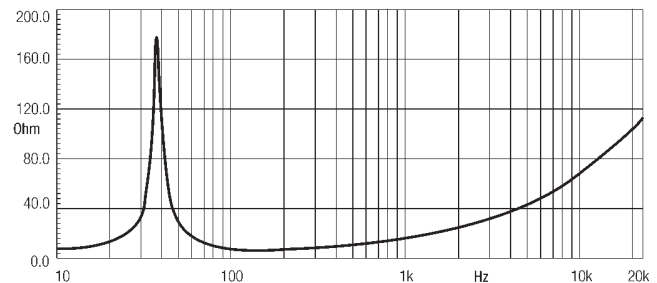

### NOTES

- (1) AES power is determined according to AES2-1984 (r2003) standard
- (2) Program power rating is measured in 125 lit enclosure tuned 50Hz using a 40 - 400Hz band limited pink noise test signal with 50% duty cycle, applied for 2 hours.
- (3) The peak power rating represents the maximum permitted instantaneous peak power level over a maximum period of 10ms which will be withstood by the loudspeaker without damage.
- (4) Sensitivity represents the averaged value of acoustic output as measured on the forward central axis of cone, at distance 1m from the baffle panel, when connected to 2,83V sine wave test signal swept between 100Hz and 500Hz with the test specimen mounted in the same enclosure as given for (1) above.
- (5) Frequency range is given as the band of frequencies delineated by the lower and upper limits where the output level drops by 10 dB below the rated sensitivity in half space environment.
- (6) Power compression represents the loss of sensitivity for the specified power, measured from 50-500 Hz, after a 5 min pink noise preconditioning test at the specified power.
- (7) Thiele - Small parameters are measured after the test specimen has been conditioned by 1000 W AES power and represent the expected long term parameters after a short period of use.
- (8) Linear Math. Xmax is calculated as  $(Hvc-Hg)/2+Hg/4$  where Hvc is the coil depth and Hg is the gap depth.

Eighteen Sound engages in research and product improvement. New materials and design refinements can be introduced into existing products without notice.