

18LW2400

Extended Low Frequency Transducer

Key Features

- 98 dB SPL 1W / 1m average sensitivity
- 100 mm (4 in) Interleaved Sandwich Voice coil (ISV)
- 2400 W program power handling
- Fiberglass reinforced cone
- Double Silicon Spider (DSS) for superior excursion control and linearity
- Double Demodulating Rings (DDR) for lower distortion
- Improved heat dissipation via multi-cell air diffractor and multiple backplate vents
- Weather protected cone and plates for outdoor usage
- Ideal for high SPL subwoofer designs



General Description

The 18LW2400 is an 18 inch extended low frequency loudspeaker designed for high SPL subwoofer applications in either a reflex, bandpass or horn loaded configuration. Compared to our industry standard 18LW1400, the 18LW2400 provides higher maximum SPL, increased program power handling and lower power compression. For optimum results we recommend amplifiers able to deliver 2400 Watt program power without clipping.

Transducer design features include a large displacement suspension system which, in conjunction with a fiberglass reinforced, straight ribbed cone and the Eighteen Sound proprietary Double Silicon Spider (DSS) technology, allows an ultra-linear piston action and provides full mechanical control across the entire working range.

The 100 mm (4 in) inside-outside copper voice coil based on Interleaved Sandwich Voice coil (ISV) technology provides high levels of thermal stability and durability.

In order to furtherly increase power handling and reduce power compression figure, 18LW2400 uses the same voice coil ventilation technology developed for our flagship 9000 neodymium transducer series. A special low density material air diffractor has been placed into the backplate acting as a cooling system, increasing power handling capability and lowering the power compression figure. As a final result Eighteen Sound engineers obtained almost 1 dB reduction in full power power compression value if compared to 18LW1400, and an increased program power handling value of 2400 Watt.

The low distortion and unmatched sound quality of the 18LW2400 has been significantly improved by Double Demodulating Rings (DDR) embedded in the pole piece of the magnetic structure. These have been designed to reduce the intermodulation and harmonic distortion while improving the transient response.

10% reduction in weight have been obtained optimizing the magnetic structure through advanced FEA CAD simulation tools.

18LW2400 is able to perform properly under inclement weather conditions: the exclusive cone treatment improves pulp strength and gives water repellent properties to both sides of the cone. In addition, the special treatment applied to top and back plates of the magnetic structure is far more resistant to the corrosive effects of salts and oxidation.

0221882400 8 Ohm
0221842400 4 Ohm

0271882400 R-kit 8 Ohm
0271842400 R-kit 4 Ohm

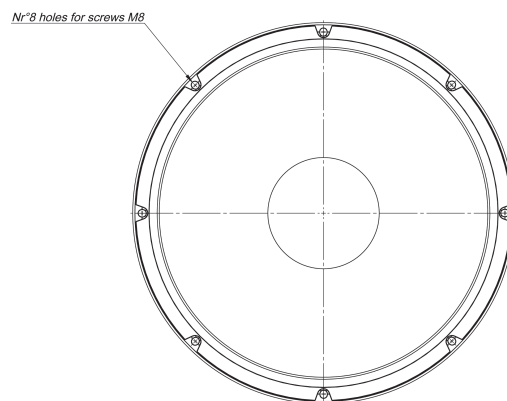
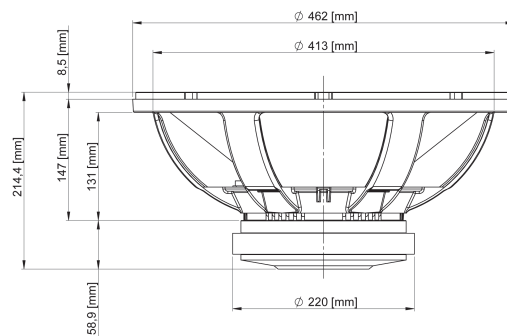

FERRITE LF-MB-MF TRANSDUCERS

18LW2400

Extended Low Frequency Transducer

GENERAL SPECIFICATIONS

NOMINAL DIAMETER	460 mm (18 in)
RATED IMPEDANCE	8 Ohm
AES POWER (1)	1200 W
PROGRAM POWER (2)	2400 W
PEAK POWER (3)	7000 W
SENSITIVITY (4)	98 dB
FREQUENCY RANGE (5)	31 - 2500 Hz
POWER COMPRESSION @-10DB (6)	0,7 dB
POWER COMPRESSION @-3DB	1,5 dB
POWER COMPRESSION @FULL POWER	2,2 dB
MAX RECOMM. FREQUENCY	500 Hz
RECOMM. ENCLOSURE VOLUME	130 ÷ 350 lt. (4,59 ÷ 12,36 cuft)
MINIMUM IMPEDANCE	6,3 Ohm at 25°C
MAX PEAK TO PEAK EXCURSION	50 mm (1,97 in)
VOICE COIL DIAMETER	100 mm (4 in)
VOICE COIL WINDING MATERIAL	copper
SUSPENSION	Triple roll, Polycotton
CONE	Straight ribbed, fiberglass reinforced cellulose

THIELE SMALL PARAMETERS (7)

Fs	35 Hz
Re	5 Ohm
Sd	0,1225 sq. mt. (189,88 sq. in.)
Qms	7,2
Qes	0,32
Qts	0,31
Vas	230 lt. (8.12 cuft)
Mms	192 gr. (0,42 lb)
BL	25,6 Tm
Linear Mathematical Xmax (8)	± 9,5 mm (± 0,38 in)
Le (1kHz)	1,35 mH
Ref. Efficiency 1W@1m (half space)	96,7 dB

MOUNTING INFORMATION

Overall diameter	462 mm (18,18 in)
N. of mounting holes	8
Mounting holes diameter	8,5 mm (0,33 in)
Bolt circle diameter	438-440 mm (17,24-17,32 in)
Front mount baffle cutout ø	416 mm (16,38 in)
Rear mount baffle cutout ø	422 mm (16,61 in)
Total depth	214,4 mm (8,44 in)
Flange and gasket thickness	24,5 mm (0,96 in)
Net weight	11,9 kg (26,18 lb)
Shipping weight	13,5 kg (29,7 lb)
CardBoard Packaging dimensions	482 x 482 x 257 mm (19 x 19 x 10,1 in)

FREQUENCY RESPONSE CURVE OF 18LW2400 MADE ON 180 LIT. ENCLOSURE TUNED 35HZ IN FREE FIELD (4PI) ENVIRONMENT. ENCLOSURE CLOSES THE REAR OF THE DRIVER. THE THIN LINE REPRESENTS 45 DEG. OFF AXIS FREQUENCY RESPONSE.

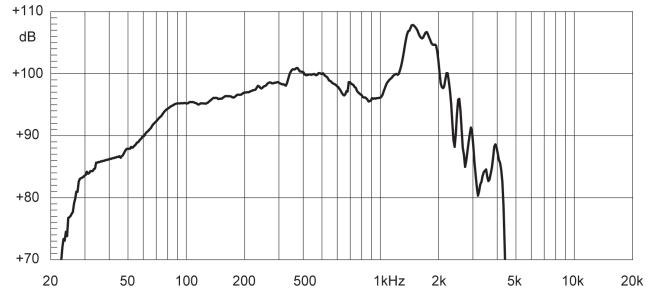

FREE AIR IMPEDANCE MAGNITUDE CURVE

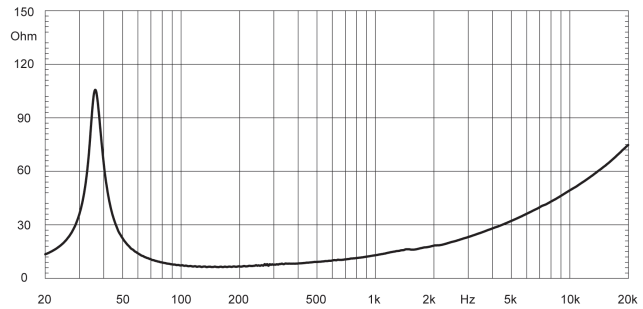

NOTES

- (1) AES power is determined according to AES2-1984 (r2003) standard
- (2) Program power rating is measured in 180 lit enclosure tuned 35Hz using a 40 - 400Hz band limited pink noise test signal with 50% duty cycle, applied for 2 hours.
- (3) The peak power rating represents the maximum permitted instantaneous peak power level over a maximum period of 10ms which will be withstood by the loudspeaker without damage.
- (4) Sensitivity represents the averaged value of acoustic output as measured on the forward central axis of cone, at distance 1m from the baffle panel, when connected to 2,83V sine wave test signal swept between 100Hz and 500Hz with the test specimen mounted in the same enclosure as given for (1) above.
- (5) Frequency range is given as the band of frequencies delineated by the lower and upper limits where the output level drops by 10 dB below the rated sensitivity in half space environment.
- (6) Power compression represents the loss of sensitivity for the specified power, measured from 40-400 Hz, after a 5 min pink noise preconditioning test at the specified power.
- (7) Thiele - Small parameters are measured after the test specimen has been conditioned by 1200 W AES power and represent the expected long term parameters after a short period of use.
- (8) Linear Math. Xmax is calculated as $(Hvc-Hg)/2 + Hg/4$ where Hvc is the coil depth and Hg is the gap depth.

Eighteen Sound engages in research and product improvement. New materials and design refinements can be introduced into existing products without notice.